



MR CONDITIONAL
*CAN I SCAN THIS
PATIENT?*

Can I scan this patient?



Terminology

In an effort to clarify the terminology and, more importantly, because the misuse of these items could result in serious accidents, the MR task group of the American Society for Testing and Materials (ASTM) International developed a new set of terms in 2005.

MR Safe

MR Conditional

MR Unsafe

MR Conditional

MR Conditional - an item that has been demonstrated to pose no known hazards in a specified MRI environment with specified conditions of use.

First Thing

“Do you have the product safety information?”

“Yes? Send it to me.”

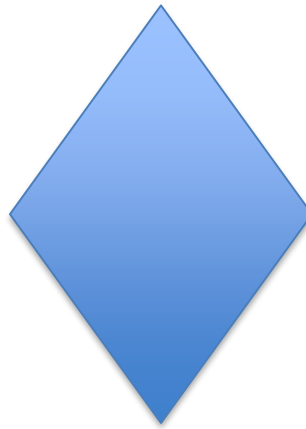

“No, I’ll try to look it up.”

Looking it up

- Call the device manufacturer directly.
- Browse the internet for the device and its safety information.
- Use Internet MRI safety sites.

Note Bene

Subscribe to an MRI Safety service, or build your own data base.

If you have multiple sites, this is even more important.

Establish it on-line, and keep it updated.

ACME Overthruster

MRI SAFETY INFORMATION

- Non-clinical testing has demonstrated that the ACME Overthruster is MR Conditional. It can be scanned safely under the following conditions. Scanning under other conditions may result in severe patient injury or device malfunction.

Static magnetic field of 1.5 Tesla only

Maximum spatial gradient field of 300 Gauss/cm ($3 T/m$)

Maximum switched gradient slew rate per axis of 200 mT/m/ms

Maximum switched gradient amplitude per axis of 45 mT/m

Maximum MR System reported whole body averaged specific absorption rate (SAR) of 2.0 W/kg
(*Normal Operating Mode*)

ACME Overthruster

MRI SAFETY INFORMATION

- Non-clinical testing has demonstrated that the ACME Overthruster is MR Conditional. It can be scanned safely under the following conditions. Scanning under other conditions may result in severe patient injury or device malfunction.

Static magnetic field of 1.5 Tesla only

Maximum spatial gradient field of 300 Gauss/cm (3 T/m)

Maximum switched gradient slew rate per axis of 200 mT/m/ms

Maximum switched gradient amplitude per axis of 45 mT/m

Maximum MR System reported whole body averaged specific absorption rate (SAR) of 2.0 W/kg
(Normal Operating Mode)

Field Strength

Other options;

up to 3T,

at 1.5 T and 3 T only

up to 1.0 T

ACME Overthruster

MRI SAFETY INFORMATION

- Non-clinical testing has demonstrated that the ACME Overthruster is MR Conditional. It can be scanned safely under the following conditions. Scanning under other conditions may result in severe patient injury or device malfunction.

Static magnetic field of 1.5 Tesla only

Maximum spatial gradient field of 300 Gauss/cm (3 T/m)

Maximum switched gradient slew rate per axis of 200 mT/m/ms

Maximum switched gradient amplitude per axis of 45 mT/m

Maximum MR System reported whole body averaged specific absorption rate (SAR) of 2.0 W/kg
(Normal Operating Mode)

SPATIAL FIELD GRADIENT

The magnetic field around an MRI unit changes with distance, increasing as it nears the magnet. This results in a gradient, a change in the field over distance.

It is sometimes referred to as the slope of the magnetic field.

Isogauss contours

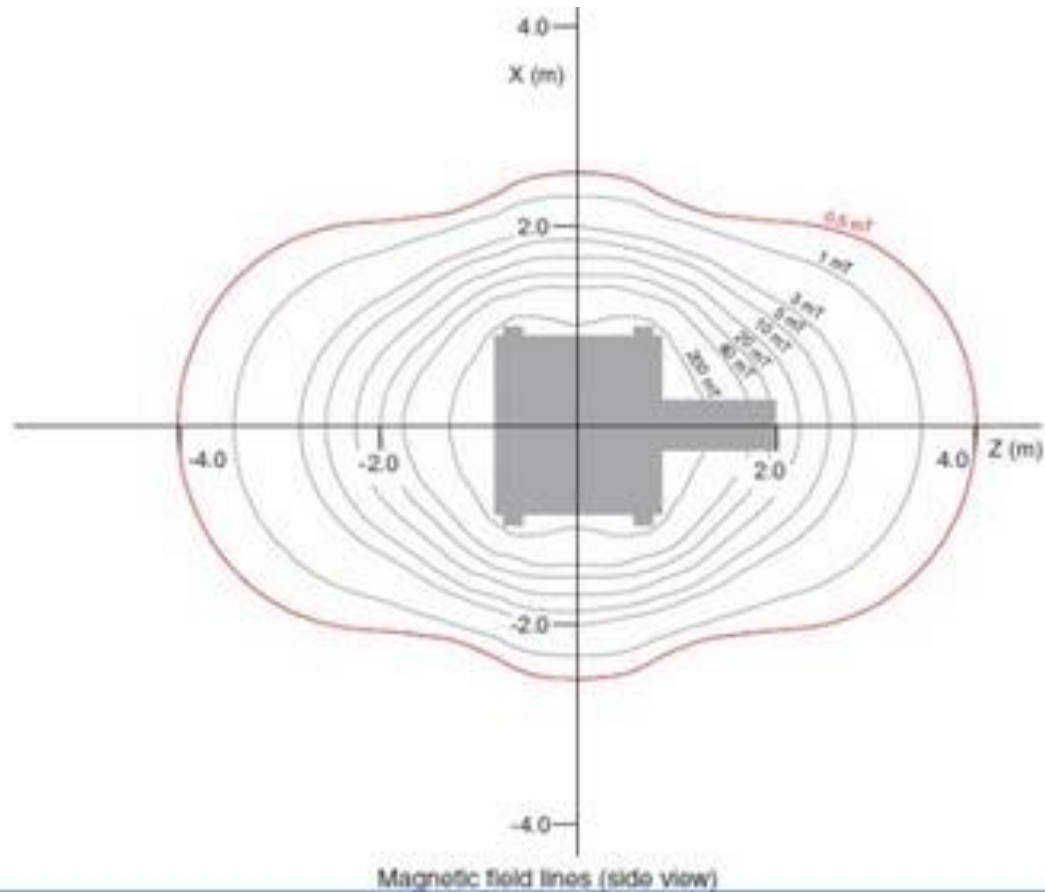

SPATIAL FIELD GRADIENT

The concern is that the increased 'slope' of the magnetic field may cause excessive stress on an implant or device, causing it to become displaced.

Therefore, manufacturers have imposed limits as to how much "stress" their objects can withstand.

This is established through a Condition, the maximum spatial field gradient allowable.

Maximum Spatial Gradient - Device manufacturers

The maximum spatial gradient refers to the spatial gradient at the location of deflection.



Measurement of Spatial Gradient.

if the object is deflected more than 45-degrees, the deflection force is greater than the force of gravity and it is assumed that a risk of deflection is present

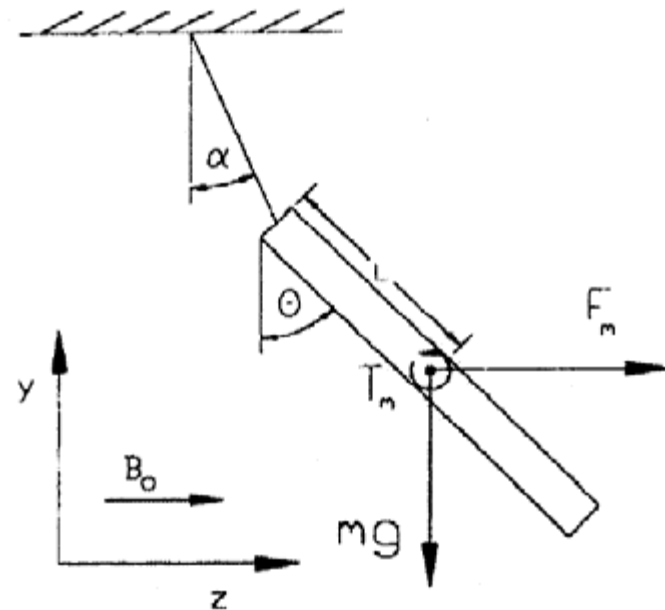

FIG. 2 Test Device in Magnetic Field

Maximum Spatial Gradient - Manufacturer

The maximum spatial gradient is the place of maximum 'slope'.

This will be located at a point within the covers or shroud of the MR scanner.

This location is not one that can be reached by a patient and does not represent a reasonable assessment of risk exposure for that situation.

WHERE WILL THE OBJECT BE IN
THE SCANNER?

WHAT MAGNETIC ENVIRONMENT
WILL IT ENCOUNTER?

SPATIAL FIELD GRADIENT

To assist, scanner manufacturers have developed documentation for their units.

Spatial Gradient Strengths – TOSHIBA Vantage

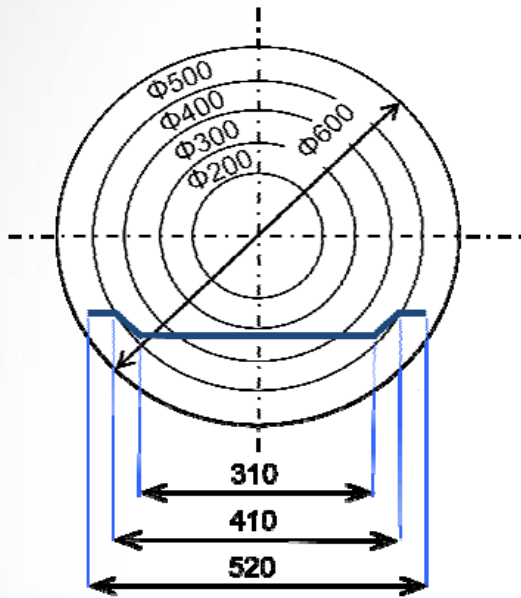

	Vantage	
	Gauss/cm	T/m
On isocenter	236	2.36
Cylindrical diameter of 20cm	247	2.47
Cylindrical diameter of 30cm	264	2.64
Cylindrical diameter of 40cm	291	2.91
Cylindrical diameter of 50cm	338	3.38
Cylindrical diameter of 60cm	426	4.26
Cylindrical diameter of 65cm	523	5.23

SIEMENS AVANTO Side View

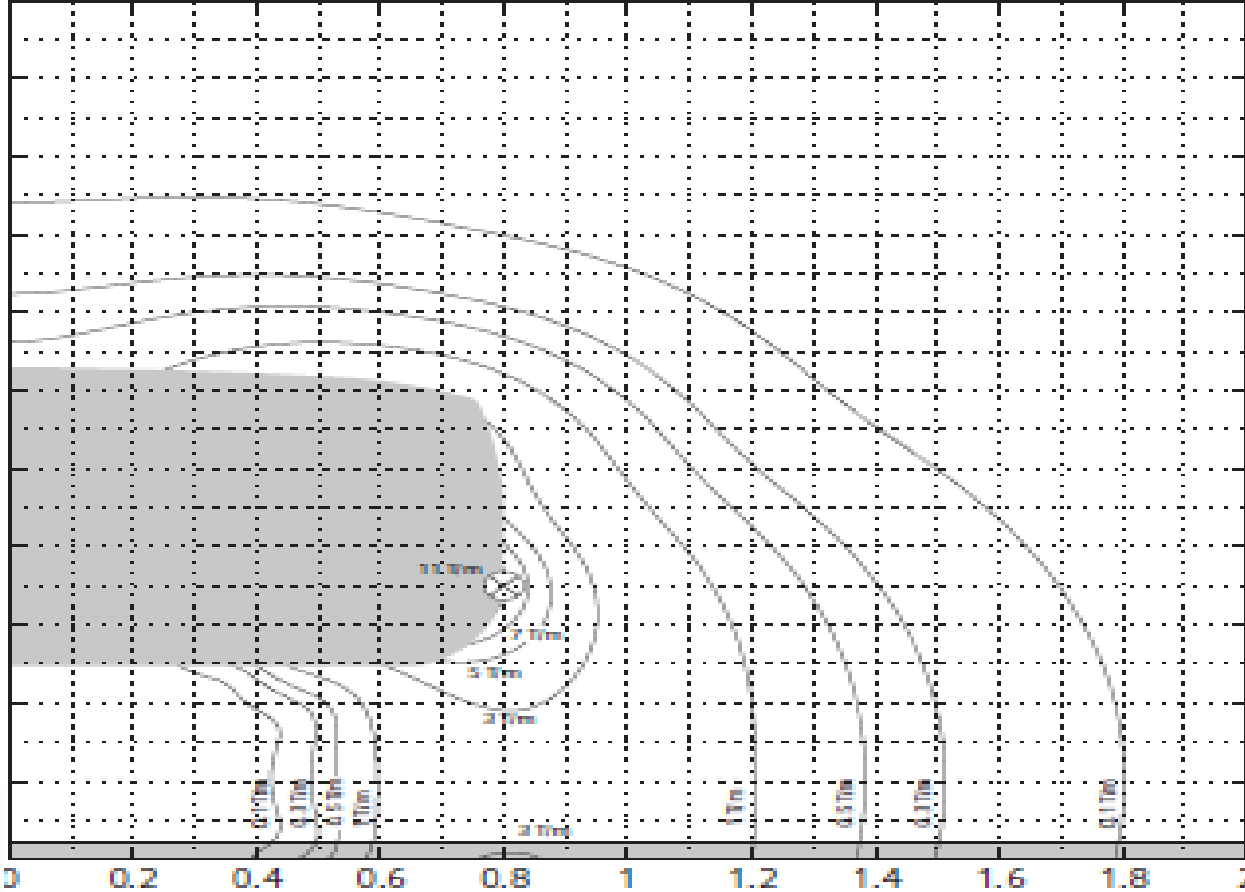

SIEMENS

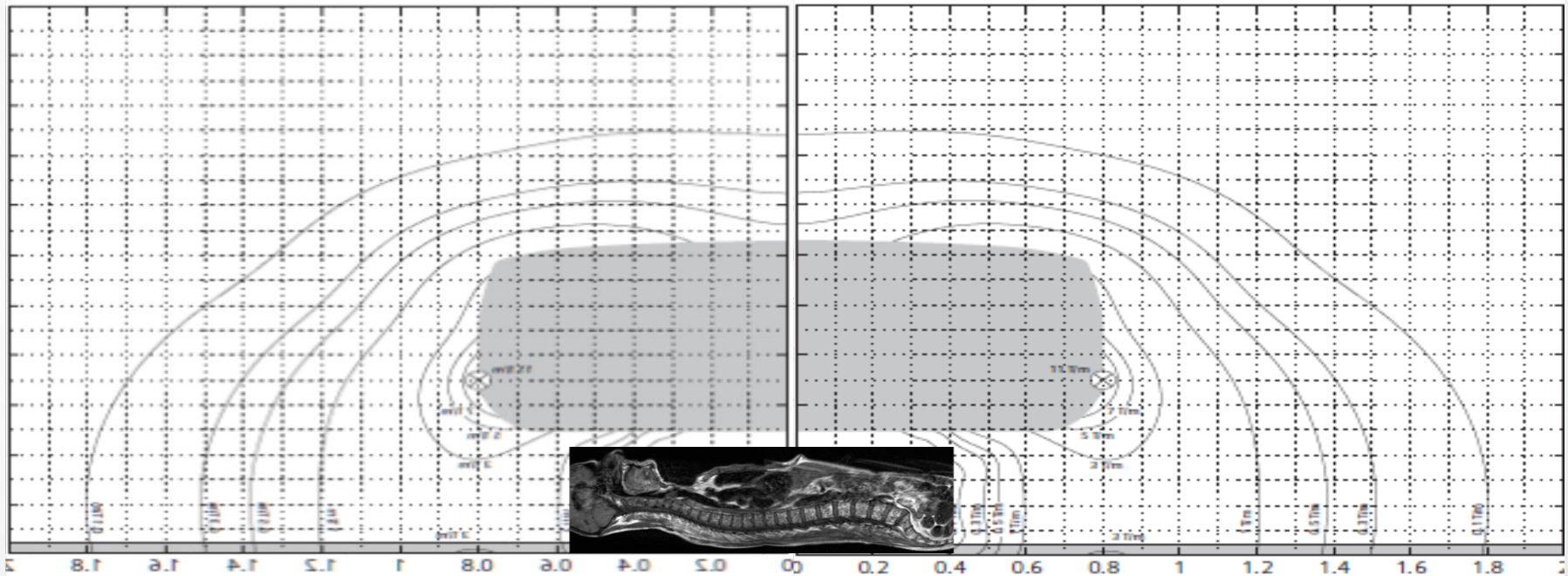

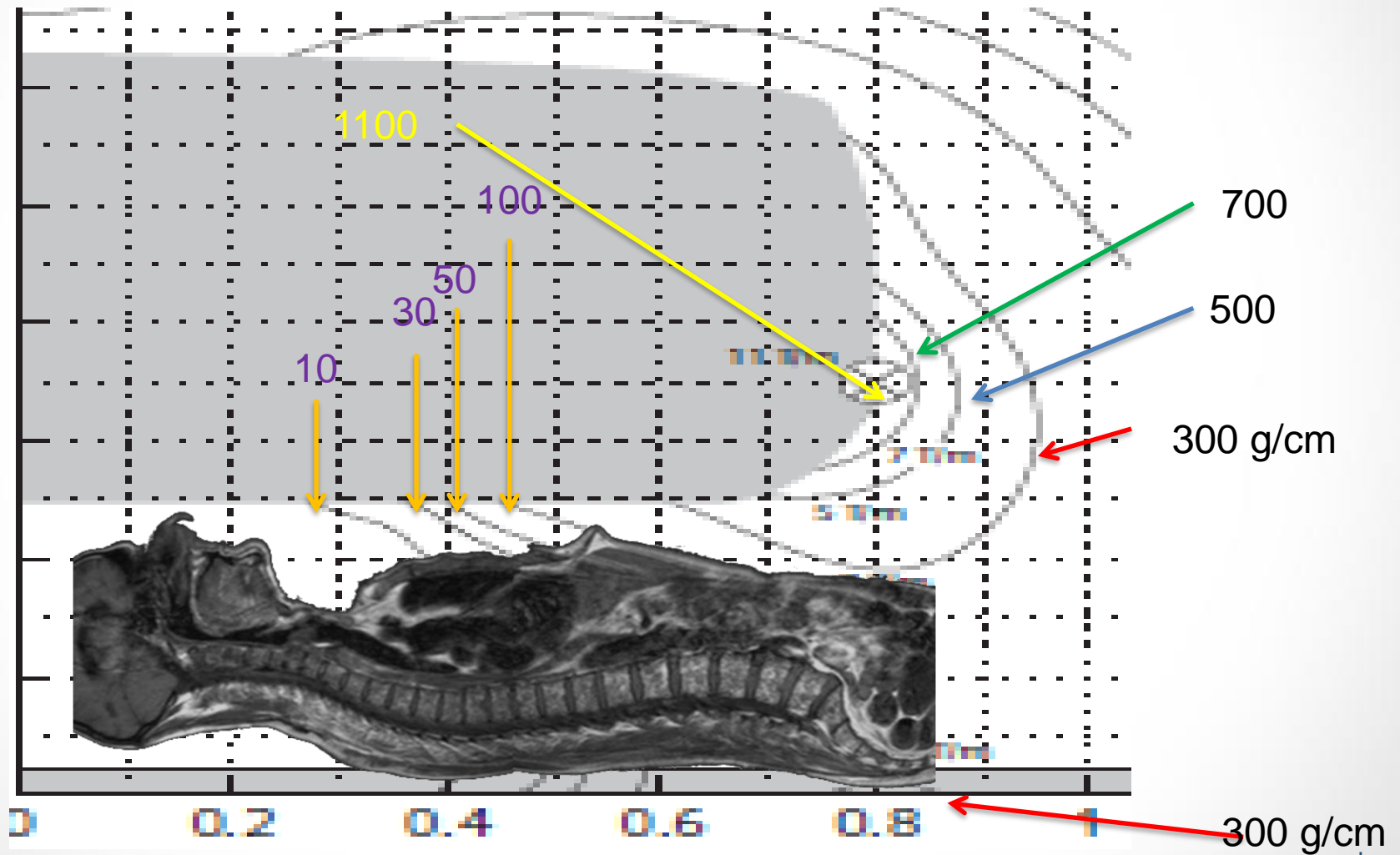
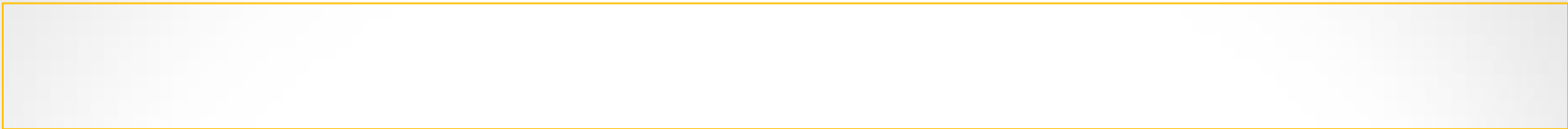

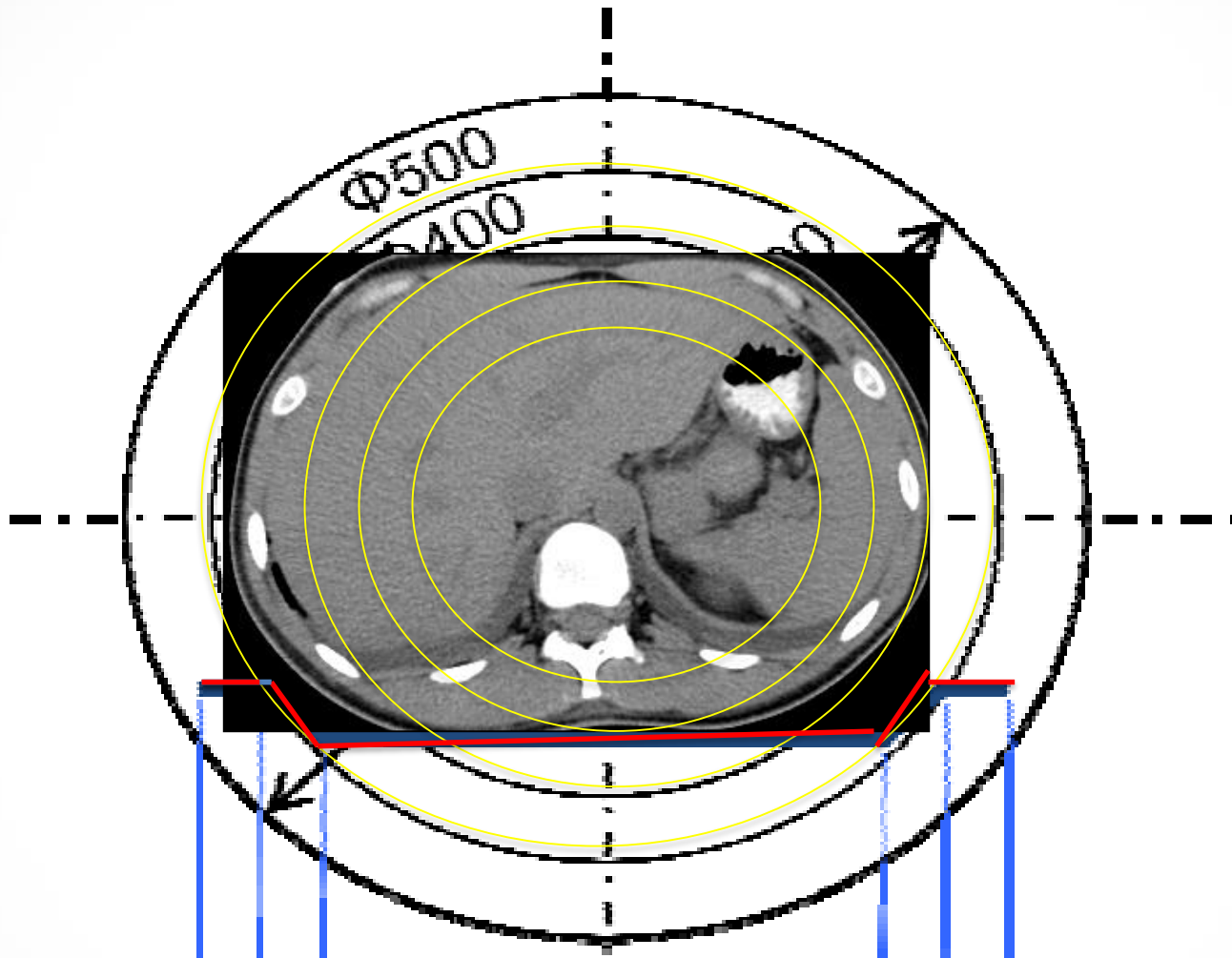

ACME Overthruster

MRI SAFETY INFORMATION

- Non-clinical testing has demonstrated that the ACME Overthruster is MR Conditional.
It can be scanned safely under the following conditions. Scanning under other conditions may result in severe patient injury or device malfunction.

Static magnetic field of 1.5 Tesla only

Maximum spatial gradient field of 300 Gauss/cm (3 T/m)

Maximum switched gradient slew rate per axis of 200 mT/m/ms

Maximum switched gradient amplitude per axis of 45 mT/m

Maximum MR System reported whole body averaged specific absorption rate (SAR) of 2.0 W/kg
(*Normal Operating Mode*)

SAR

Specific Absorption Rate

The Specific Absorption Rate is the RF power absorbed per unit of mass of an object, and is measured in watts per kilogram (W/kg).

It relates to the direct heating of a device, through the absorption of rf energy.

SAR

The FDA has established SAR limits for MRI:

Whole body: 4W/kg/15-minute exposure averaged

Head: 3W/kg/10-minute exposure averaged

Head or torso: 8W/kg/5 minute exposure per gram of tissue

Extremities: 12W/kg/5 minute exposure per gram of tissue

SAR

Operating modes

The industry has established three operating modes or levels for MRI

Normal operating mode: Less than or equal to 2W/kg.

- First level controlled operating mode: Greater than 2W/kg up to 4W/kg..
- Second level controlled operating mode: Greater than 4W/kg. Second level controlled mode requires IRB approval.

SAR

When the operator enters the patient's weight, the scanner automatically calculates the expected SAR for the exam sequences.

Occasionally, a particular protocol might result in an SAR in excess of the limits. The operator will receive a notification of this. In this case, alterations to the parameters must be made.

SAR

Tools for lowering SAR

Increase TR

Decrease bandwidth

Decrease pulse angle, (a 50% decrease cuts SAR by 4)

Decrease Nex

Decrease phase encoding steps

Don't use fast echo sequences

Field strength is also a factor. The SAR at 3T is 4 times as high for the same sequence at 1.5 T.

Potential Language

Additional instructions essential to safe use in the MR environment:

Under the scan conditions defined above, the BIM400 Implant Magnet is expected to produce a maximum temperature rise of 2.1°C after 15 minutes of continuous scanning.

In non-clinical testing, the BIM400 Implant Magnet produced a temperature rise of less than 2.1°C (*extrapolated*) at a maximum whole body averaged specific absorption rate (SAR) of 2.0 W/kg (*extrapolated*) assessed by calorimetry for 15 minutes of MR scanning in a 1.5 Tesla Intera, Philips Medical Systems (*Software: 12.6.1.3, 2010-12-02*) MR Scanner.

In non-clinical gradient-induced heating testing, the BIM400 Implant Magnet produced a temperature rise (*extrapolated*) of less than 4.5°C at a time rate of change of the theoretical maximum worst-case gradient magnetic field dB/dt (*extrapolated*) of 200 T/s during 30 min. of continuous exposure in a test laboratory system (*Pulsed Magnetic Field Generator*) equivalent with a gradient system of a 1.5 Tesla MR system.

In non-clinical testing with the implant magnet in place, the image artefact caused by the device extends approximately 11.5 cm (*4.5 in.*) from the BIM400 Implant Magnet when imaged with a gradient echo pulse sequence and a 1.5 Tesla MRI system

ACME Overthruster

MRI SAFETY INFORMATION

- Non-clinical testing has demonstrated that the ACME Overthruster is MR Conditional. It can be scanned safely under the following conditions. Scanning under other conditions may result in severe patient injury or device malfunction.

Static magnetic field of 1.5 Tesla only

Maximum spatial gradient field of 26600 Gauss/cm (*266 T/m*)

Maximum switched gradient slew rate per axis of 200 mT/m/ms

Maximum switched gradient amplitude per axis of 45 mT/m

B1+RMS limit of $\leq 2.8\mu\text{T}$

B1+rms

B1+RMS is the time-averaged RF magnetic field component that is generated by the scanner during a scan. It is measured in units of micro-Tesla (μT).

It is considered to be a more precise RF exposure metric than SAR because it is patient independent.

It is increasingly being used as a condition of use, although on older scanners and software versions, it might not be readily located.

Possible Conditions

Maximum RF power of 2.0 μT B1+rms (B+root mean squared)

If B1+rms is not available, a maximum RF power of 2.0 W/kg whole body and head SAR (specific absorption rate). Using a SAR setting may result in a more restrictive MRI scan.

HEATING

Piercings/Implants

Concerns

Magnetic?

Heating?

Obvious choice is to remove it.

Some patients can't/won't remove it.

1. Determine where the object will be in relation to transmission.
2. Cold, wet, compresses.
3. Inform the patient to let you know of discomfort.
4. Demand they remove it.
5. Make a decision. Yes, No.

HEATING

The antenna effect

Leads, wires, etc. can act as antennae.

The issue is coupling with the electric field and channeling energy, (heat) to their tips.

The calculation is wavelength dependent, so frequency dependent, so field strength dependent.

ACME Overthruster

MRI SAFETY INFORMATION

- Non-clinical testing has demonstrated that the ACME Overthruster is MR Conditional. It can be scanned safely under the following conditions. Scanning under other conditions may result in severe patient injury or device malfunction.

Static magnetic field of 1.5 Tesla only

Maximum spatial gradient field of 300 Gauss/cm ($3 T/m$)

Maximum switched gradient slew rate per axis of 200 mT/m/ms

Maximum switched gradient amplitude per axis of 45 mT/m

Maximum MR System reported whole body averaged specific absorption rate (SAR) of 2.0 W/kg
(*Normal Operating Mode*)

Only transmit/receive head coil.

Coils

The conditions may limit the coil to be used, such as to be used only with a head coil, or, more commonly, to establish which coil can be used for transmission; whether the Body coil can be used, or a local transmit/receive coil is indicated.

ACME Overthruster

MRI SAFETY INFORMATION

- Non-clinical testing has demonstrated that the ACME Overthruster is MR Conditional. It can be scanned safely under the following conditions. Scanning under other conditions may result in severe patient injury or device malfunction.

Static magnetic field of 1.5 Tesla only

Maximum spatial gradient field of 300 Gauss/cm (3 T/m)

Maximum switched gradient slew rate per axis of 200 mT/m/ms

Maximum switched gradient amplitude per axis of 45 mT/m

Maximum MR System reported whole body averaged specific absorption rate (SAR) of 2.0 W/kg
(Normal Operating Mode)

Slew Rate

The time varying magnetic fields may induce a localized electric field in the patient.

The parameter of concern is how fast the magnetic field changes.

This is called the gradient slew rate, and is measured in:
T/m/s.

PERIPHERAL NERVE STIMULATION (PNS)

Patients sometimes feel a tingling sensation.

This is PNS.

The worry is that at high levels of induction, this might lead to pain, or even cardiac interference.

This is one of the issues with scanning at very high field strengths.

PNS

The gradient slew rate can be calculated.

The scanner manufacturer will specify the maximum gradient strength. This is usually in the area of 30-45 mT/m.

The rise time, the time it takes for the gradient to change from 0-maximum, will also be specified. This is usually in the area of 0.1-0.3 ms.

$$\frac{\text{Maximum gradient strength}}{\text{rise time}}$$

ACME Overthruster

MRI SAFETY INFORMATION

- Non-clinical testing has demonstrated that the ACME Overthruster is MR Conditional. It can be scanned safely under the following conditions. Scanning under other conditions may result in severe patient injury or device malfunction.

Static magnetic field of 1.5 Tesla only

Maximum spatial gradient field of 300 Gauss/cm (3 T/m)

Maximum switched gradient slew rate per axis of 200 mT/m/ms

Maximum switched gradient amplitude per axis of 45 mT/m

Maximum MR System reported whole body averaged specific absorption rate (SAR) of 2.0 W/kg
(Normal Operating Mode)

PNS

There is no FDA limit for this factor.

The most commonly seen value seems to be 200 T/m/s
(mT/m/ms).

When operating in Normal mode, it is highly unlikely that rates of this magnitude will be experienced.

PNS

Sequences with rapidly switching gradients are most likely to produce PNS

Echo Planar

Diffusion

THE PACEMAKER ISSUE

Cardiac implantable electronic devices (CIEDs)

cardiac pacemakers,
implantable cardioverter-defibrillators(ICD),
implantable cardiovascular monitors (ICM)
implantable loop recorders (ILR).

CIED'S

People with CIED'S must be restricted from crossing the 5 g line.

Conventional Wisdom

Patients with implanted CIED's cannot undergo an MRI study.

CIED'S

MR Conditional Pacemakers

There now are several MR conditional pacemakers on the market.

Revo MRI™ SureScan® Pacing System Conditions for Use

A complete SureScan pacing system including a Revo MRI SureScan IPG and two CapSureFix® MRI SureScan leads is required for use in the MRI environment. Any other combination may result in a hazard to the patient during an MRI scan. The SureScan feature must be programmed to On prior to scanning a patient according to the specified conditions for use.

Cardiology requirements:

- no previously implanted (active or abandoned) medical devices, leads, lead extenders, or lead adaptors
- no broken leads or leads with intermittent electrical contact as confirmed by lead impedance history
- a SureScan pacing system that has been implanted for a minimum of 6 weeks
- a SureScan pacing system implanted in the left or right pectoral region
- pacing capture thresholds of ≤ 2.0 volts (V) at a pulse width of 0.4 milliseconds (ms)
- a lead impedance value of ≥ 200 ohms (Ω) and $\leq 1,500 \Omega$
- no diaphragmatic stimulation at a pacing output of 5.0 V and at a pulse width of 1.0 ms in patients whose device will be programmed to an asynchronous pacing mode when MRI SureScan is On

Radiology requirements:

- Horizontal cylindrical bore magnet, clinical MRI systems with a static magnetic field of 1.5 Tesla (T) must be used
- Gradient systems with maximum gradient slew rate performance per axis of ≤ 200 Teslas per meter per second (T/m/s) must be used
- The scanner must be operated in Normal Operating Mode:
- the whole body averaged specific absorption rate (SAR) must be ≤ 2.0 watts per kilogram (W/kg)
- the head SAR must be < 3.2 W/kg
- The patient must be positioned within the bore such that the isocenter (center of the MRI bore) is superior to the C1 vertebra or inferior to the T12 vertebra
- Proper patient monitoring must be provided during the MRI scan. The methods include visual and verbal contact with the patient, electrocardiography, and pulse oximetry (plethysmography)

Training requirements:

- A health professional who has completed cardiology SureScan training must be present during the programming of the SureScan feature
- A health professional who has completed radiology SureScan training must be present during the MRI scan

CIED'S

MRI Unsafe pacemakers

Scans are being performed.

This practice is becoming more prevalent through the nation. While the manufacturers do not approve it, those practicing it are following very specific procedures, including;

The patient cannot be pacemaker dependent. (In fact, the pacemaker will be “deactivated” during the scan.)

The patient must have no abandoned leads.

A representative from electrophysiology or Cardiology must be present to be able to address problems with the patient/pacemaker.

ADDITIONAL CONDITIONS

Be aware.

Image Artifacts

MR image quality may be compromised if the area of interest is within approximately 80 mm of the clip(s) as found in non-clinical testing using a spin echo and gradient echo pulse sequence in a 3T MR system (Philips Medical Systems, Best, The Netherlands, Achieva, software 2.6.3.7 2010-11-24). Therefore, it may be necessary to optimize MR Imaging parameters in the presence of this implant.

Disconnect all cables and patient EEG monitor from the electrodes prior to entering the MRI environment.

Horizontal cylindrical bore magnet, clinical MRI systems with a static magnetic field of 1.5 Tesla (T) must be used

RECOMMENDATIONS

1. Subscribe to an MRI safety data base, or develop your own.
2. Obtain Spatial Field Gradient maps for all units.
3. Assess if your units display B1+rms.
4. Establish global policy/procedures for scanning patients with piercings, anchors, etc.
5. Determine Maximum Slew Rate for your units.