



Hybrid Magnetic Resonance/Computed Tomography Compatible Phantom for Magnetic Resonance Guided Radiotherapy

Min-Joo Kim^{1,2}, Sohyun Ahn¹, Seu-Ran Lee¹ and Tae Suk Suh¹

¹Department of Radiation Oncology, Yonsei Cancer Center, Yonsei University College of Medicine, Yonsei University Health System, Seoul, Korea ²Department of Biomedical Engineering, Research Institute of Biomedical Engineering, The Catholic University of Korea College of Medicine, Seoul, Korea



Hypothesis & Purpose

❖ Hypothesis and Introduction

- MRI-only based radiotherapy which means that application of magnetic resonance image into radiation treatment target delineation, has been increased because MR image offers superior soft tissue contrast compared to CT image, especially, for head and neck tumors, prostate, lung tumors and brain lesions
- Hypothesize that one single phantom named hybrid MR/CT compatible phantom used for acquisition of MR and conventional CT image could be applied for MR-only radiation treatment in terms of target delineation and radiation dose calculation
- Time consuming, extra costs and registration accuracy associated with multiple imaging modality remains to be solved to fully establish MR image based radiation treatment and another more critical challenge is lack of ED information of MR image for dose calculation
- Develop various tissue equivalent samples on each MR and CT image and inserted in the hybrid MR/CT compatible phantom
- Represent could represent tissue equivalently measured data for each signal intensity (SI) on MR image and HU on CT image from region of interest from one single sample on MR and CT image
- Directly applied into the conversion process from HU to relative electron density in TPS for dose calculation using the relation between SI and HU from the same sample image section

❖ Purpose

- Develop the hybrid MR/CT compatible phantom using tissue-equivalent materials on each MR and CT image for magnetic resonance only-guided radiotherapy

MATERIALS & METHODS

❖ Requirement for "MR/CT compatible phantom"

- Generally, production of MR phantom should be considerate carefully compared to making of CT phantom because the principle of MR image acquisition is much more complex than those of CT image acquisition and most of MR phantom was filled with water or copper sulfate for image quality control or MR spectroscopy
- Requirement for "MR/CT compatible phantom" was established throughout paper research

- 1) Relaxation times equivalent to human tissue
- 2) Dielectric properties
- 3) Homogeneous relaxation times
- 4) Sufficient strength to fabricate a torso
- 5) Ease of handling
- 6) A wide variety of density material
- 7) Chemical & physical stability over an extended time

❖ Chemical component for tissue equivalent material

- Carrageenan as gelling agent which was blended from various seaweeds to produce rigid gel and more elastic and resistant to cracking than agar gel, and enable for the creation of large phantom for over extended time
- Agaros as T2 modifier

- GdCl₃ as T1 modifier
- NaN₃ as an antiseptic which is highly soluble in water and very acutely toxic
- NaCl and deionized and distilled water
- K₂CO₃ as electron density modifier
- Various mixture of chemical component to simulate human tissue on both MR and CT image was tested by measuring T1, T2 relaxation time and signal intensity on MR image and HU on CT image and each value was compared with reference data

RESULTS & DISCUSSION

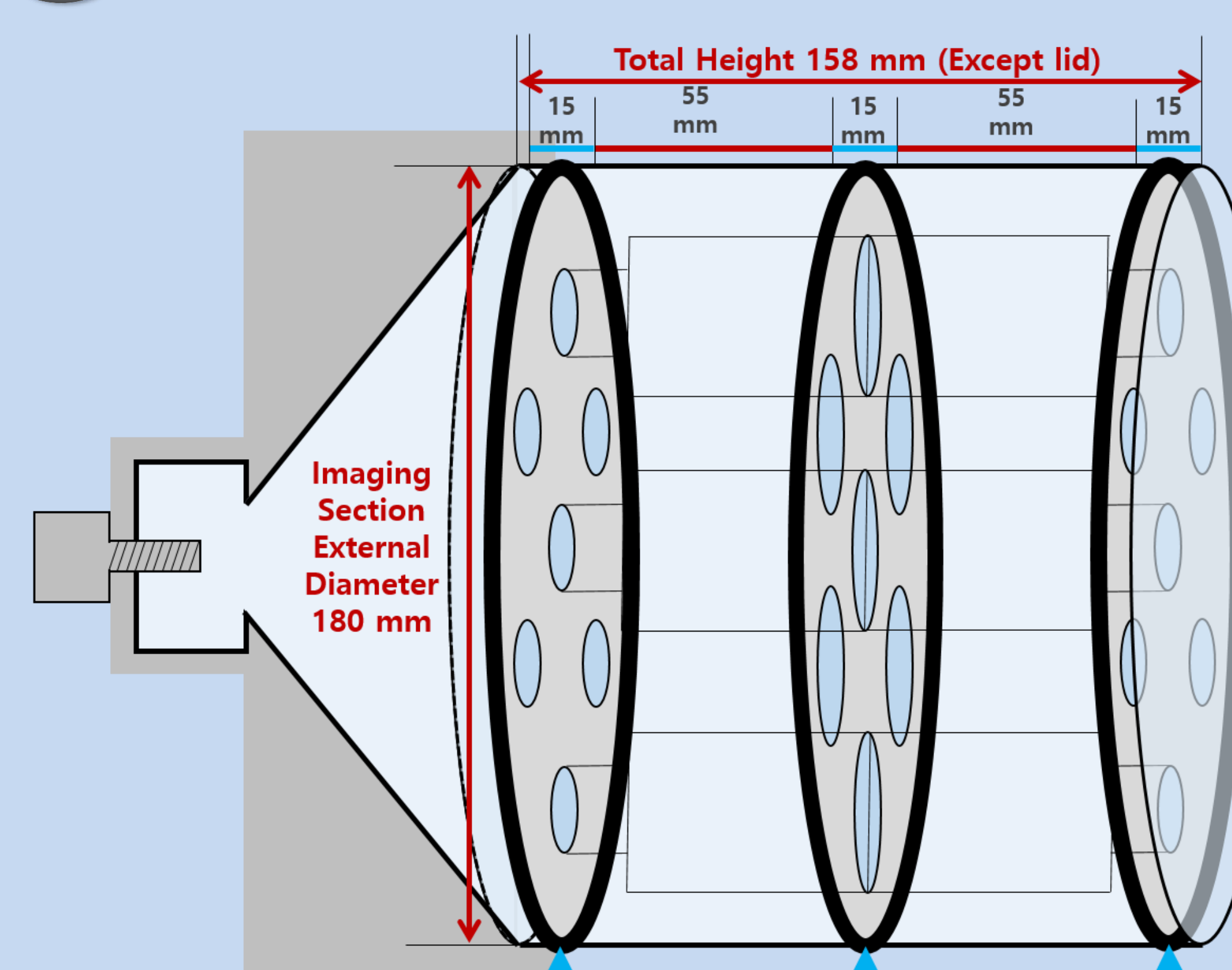

Fig.1. Geometry of the developed phantom: Total height and external diameter was decided by internal size of 8-channel MRI head coil. Two disks at both end and one disk in the middle of phantom can provide two different interspaces. 7 plugs can be located at one of the interspace between the disks. Thus, total 14 plugs can be inserted into phantom. The developed phantom was customized to fix 14 plugs with out water leakage

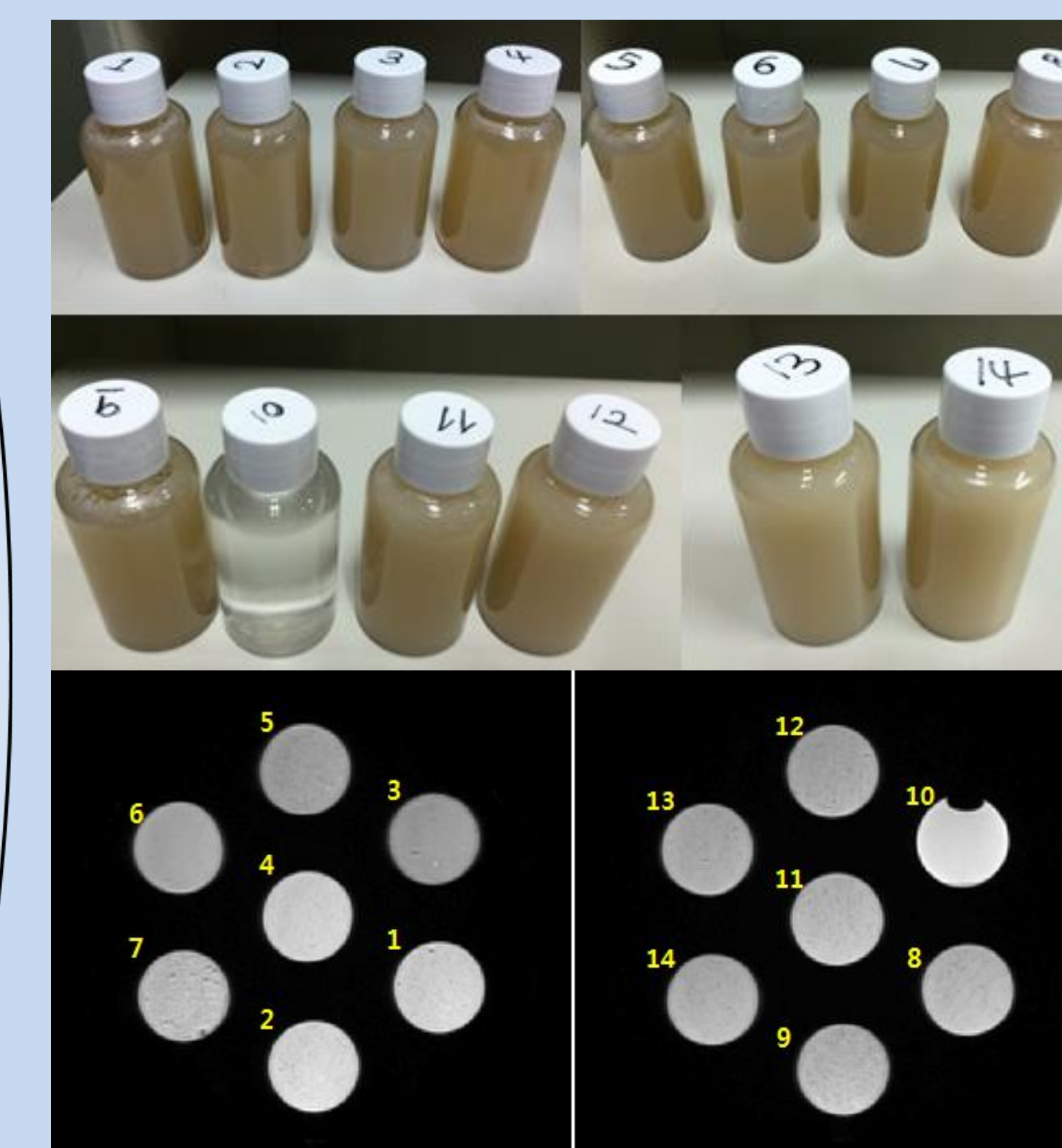

Fig.2. 14 different developed tissue-equivalent materials (Upper) and its MR image for each plug listed in Table 1 with TR 1500 ms, TE 35 ms (Lower)

- ❖ The importance of MR image phantom for radiation oncology field has been suggested. Also, to the best of our knowledge, another possible application of those tissue-equivalent materials in the field of radiation oncology, especially for radiation dose calculation, has not been reported.
- ❖ A hybrid MR/CT compatible phantom for image acquisition of MR and CT was designed and investigated the relation between MR and CT image for MR-only based radiotherapy in terms of target delineation and radiation dose calculation. In addition, various tissue-equivalent materials for both MR and CT image to be inserted into the developed phantom were described in this study.
- ❖ The modulation method of CT image and HU value was successfully developed by using K₂CO₃ since the formula to quantitatively calculate the amount of K₂CO₃ in tissue-equivalent materials for simulation of each organ and control of the HU value was deducted and the non-effectiveness of K₂CO₃ for MR image was demonstrated.
- ❖ However, T1- and T2- relaxation time of each tissue-equivalent material could not be achieved. The T1-T2 measurement data was compared with reference data and the average of percentage difference was 2.86% and -13.37% for T1- and T2 relaxation time, respectively. With the 5% of tolerance for percentage difference, 10 measurement data among 24 was acceptable and tissue-equivalent materials of liver was acceptable as tissue-equivalent materials.